

LINEO 100 (17144)

GENERAL DATA

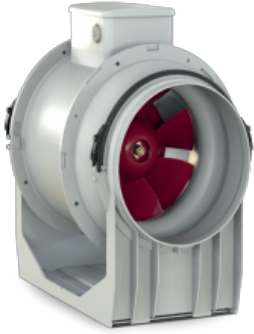

Mixed flow fans The LINEO series appliances are driven by 3-speed induction motors, useful to reach the optimal compromise between performance, fuel consumption and noise emissions. It is also possible to adjust the speed by means of one of the VORTICE devices supplied as option. Timer version available (T)

- Fire resistant plastic resin construction, class E2, according to ISO EN 11925-2:2010, in areas overlooking the engine and electrical components.
- Thermally protected induction motor, with shaft mounted on ball bearing supports, combined with a helical-centrifugal impeller.
- High degree of water resistance: IPX5 (if installed in duct).
- Controllable at speed by Vortice regulating devices.

PERFORMANCE CURVE

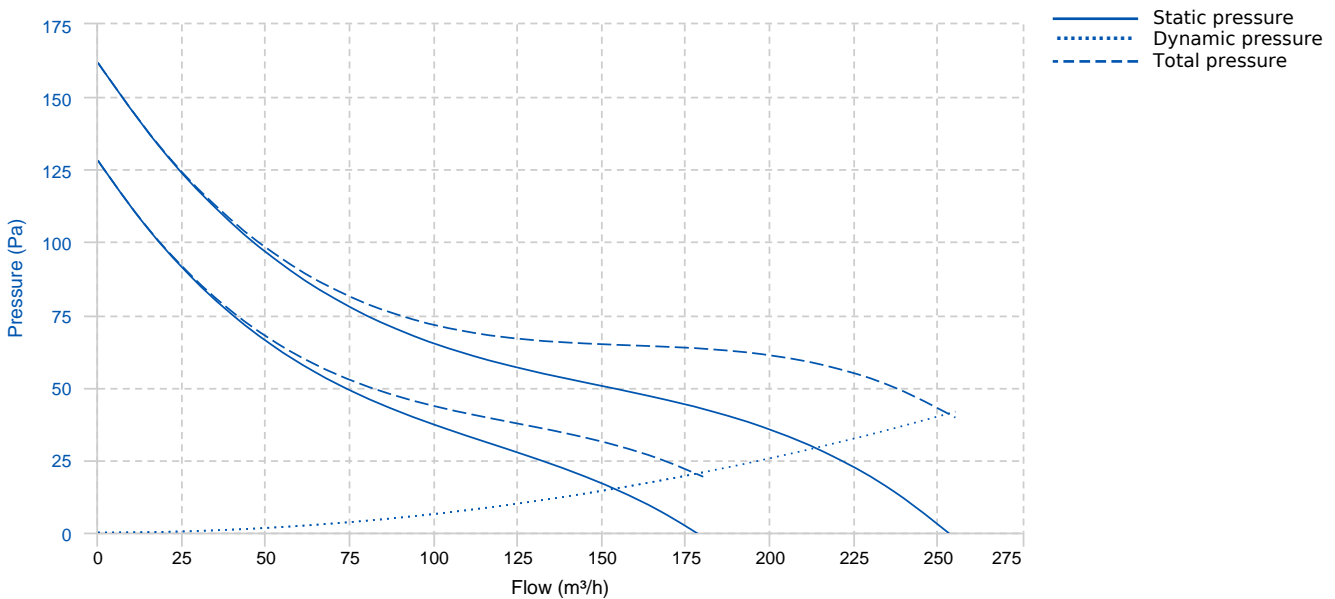

TECHNICAL DATA

Fan

Approx. weight	1.8 kg	Max. Flow	255 m³/h
----------------	--------	-----------	----------

DIMENSIONS

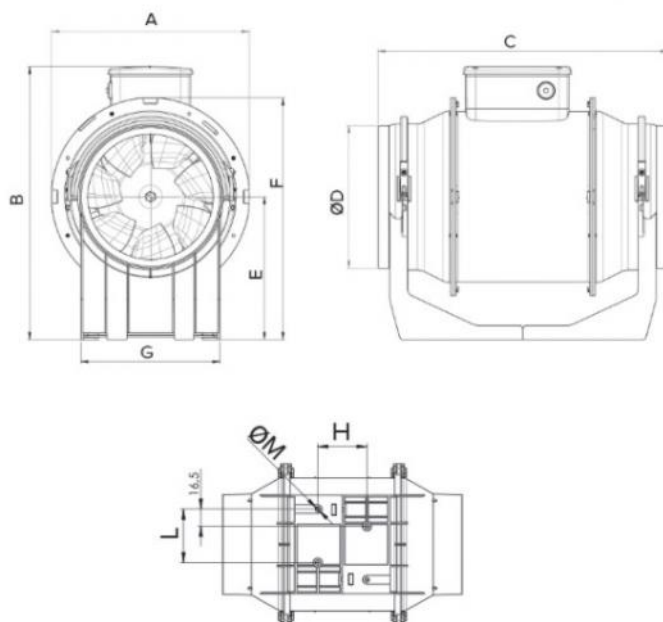

Dimensions (mm)

A	188.5	B	211	C	303	D diam.	96	E	101.5
F	189	G	90						

WIRING DIAGRAM

FOR ELECTRICAL SCHEMES
PLEASE SEE THE USER MANUAL

ACCESSORIES

**
LINEO-G 100 (protection grille)
REF: 22701

**
LINEO-PF 100 (parallel installation kit)
REF: 22577

**

LINEO-C 100 (series installation kit)
REF: 22584

CONTROLLER
IREM-D (speed controller)
REF: 12867

SENSOR
C SMOKE (smoke sensor)
REF: 12993

SENSOR
C PIR (passive infrared sensor)
REF: 12998

CONTROLLER
DUO
REF: 22914

**

IN-LINE S 100 (shutter)
REF: 22551

**

LINEO-SF 500 (series installation plate)
REF: 22593

SENSOR
C TEMP (temperature sensor)
REF: 12992

SENSOR
C HCS (humidity sensor)
REF: 12994

SENSOR
C TIMER
REF: 12999

CONTROLLER
C 1.5 (electronic speed controller)
REF: 12966