

## LINEO 150 (17146)

### GENERAL DATA

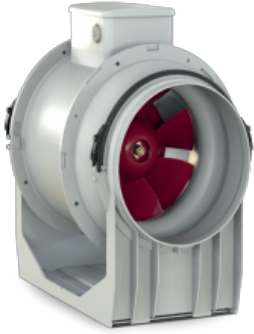

Mixed flow fans The LINEO series appliances are driven by 3-speed induction motors, useful to reach the optimal compromise between performance, fuel consumption and noise emissions. It is also possible to adjust the speed by means of one of the VORTICE devices supplied as option. Timer version available (T)

- Fire resistant plastic resin construction, class E2, according to ISO EN 11925-2:2010, in areas overlooking the engine and electrical components.
- Thermally protected induction motor, with shaft mounted on ball bearing supports, combined with a helical-centrifugal impeller.
- High degree of water resistance: IPX5 (if installed in duct).
- Controllable at speed by Vortice regulating devices.

### PERFORMANCE CURVE

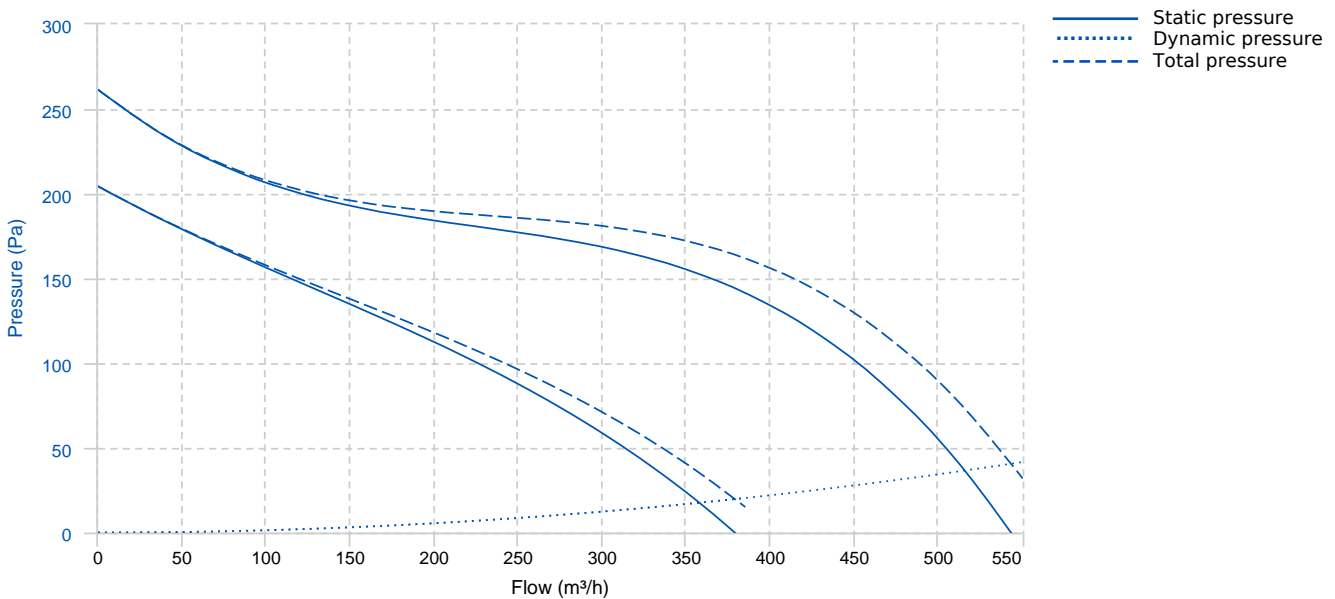

### TECHNICAL DATA

#### Fan

Approx. weight	2.4 kg	Max. Flow	550 m³/h
----------------	--------	-----------	----------

## DIMENSIONS

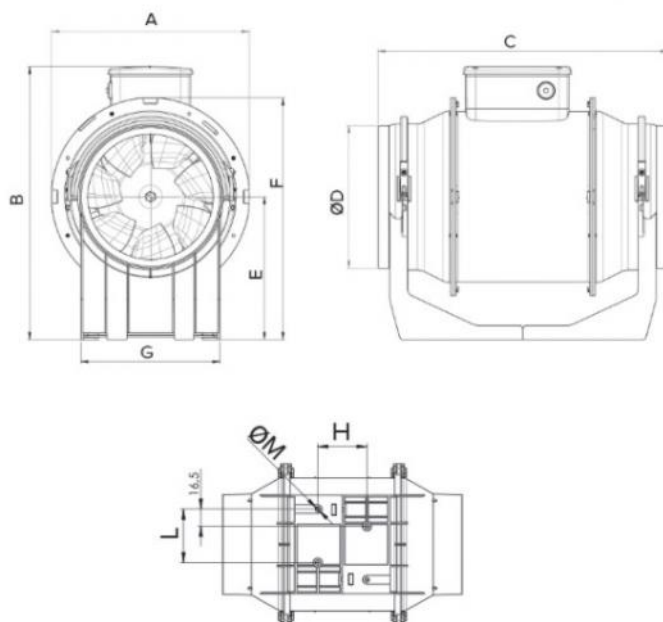

### Dimensions (mm)

A	294	B	214.5	C	294	D diam.	146	E	112.5
F	212	G	110						

## WIRING DIAGRAM

FOR ELECTRICAL SCHEMES  
PLEASE SEE THE USER MANUAL

## ACCESSORIES

\*\*  
**LINEO-G 150 (protection grille)**  
REF: 22703

\*\*  
**LINEO-PF 150 (parallel installation kit)**  
REF: 22579

\*\*

**LINEO-C 150 (series installation kit)**  
REF: 22586

**CONTROLLER**  
**IREM-D (speed controller)**  
REF: 12867

**SENSOR**  
**C SMOKE (smoke sensor)**  
REF: 12993

**SENSOR**  
**C PIR (passive infrared sensor)**  
REF: 12998

**CONTROLLER**  
**DUO**  
REF: 22914

**CONTROLLER**  
**C 2.5 (electronic speed controller)**  
REF: 12967

\*\*

**LINEO-SF 500 (series installation plate)**  
REF: 22593

**SENSOR**  
**C TEMP (temperature sensor)**  
REF: 12992

**SENSOR**  
**C HCS (humidity sensor)**  
REF: 12994

**SENSOR**  
**C TIMER**  
REF: 12999

**CONTROLLER**  
**C 1.5 (electronic speed controller)**  
REF: 12966

\*\*

**IN-LINE S 150 (shutter)**  
REF: 22562